



UPSHINE®



Technical Application
Guide for UP-SHINE
LED Downlight

UP-DL133-5&6-15W-D

Introduction



Up-shine DL133 retrofit kit adopts high lumen LM80 SMD chip and high transmittance cover which increase the luminous efficiency and makes the lighting soft. Aluminum body makes the better heat dissipation and lighter weight. 4inch, 5&6 inch full size in E26 adaptor for easier installation. Can work with triac dimmers.

- Up to 70% energy saving compared to standard CFL
- Long lifetime of 36,000 hours
- Dimmable when using triac dimmer
- 110° wide beam angle
- CCT: 2700K 3000K 4000K 5000K
- No UV/IR light
- Environment friendly, without Mercury or any other hazardous substances

Application notes

- For Damp location
- Professional electrician for installation only
- Switch off before installation
- Do not touch when in use
- Keep away from hot steam and corrosive gas

Application Areas

it has been designed to replace the traditional lamp with housing and been widely used in residential, official and commercial internal lighting area.



Product Information

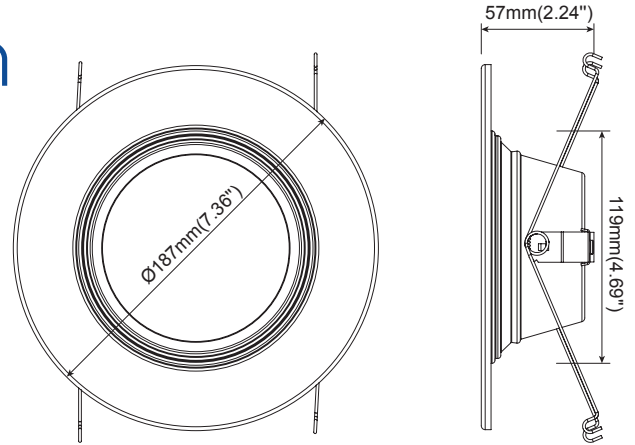

Technical Specifications

Model	Voltage	Power	Power Factor	Lumen (±5%)	CCT	Beam angle	Lifespan	CRI	Dimmable	Dimension
UP-DL133-5&6-15W-D	AC120V	15W	≥0.9	750(950)	2700K	110°	3,6000h	≥80	Yes	Ø187*57mm (7.36" * 2.24")
				780(960)	3000K					
				820(970)	3500K					
				820(970)	4000K					

Driver data Sheet

Driver data	DIM
Input rated Voltage	AC120V
Frequency	60Hz
Input Voltage	AC100-130V
Efficiency	≥75%
Total load Wattage	15W±1W
Power Factor	≥0.9
Rated input current	≤0.18A
Full load output Voltage	DC120-140V
Rated output current	90mA
Output current range	90mA±5%
Power tolerance	±5%
Current output tolerance	±5%
Dimming range	8%-100%
Dimmer	Triac dimmers
Short circuit protection	PASS
Over voltage protection	PASS
Over temperature protection	PASS
THD	—
Withstand voltage	—

Fixture Compatibility

Rated Wattage	Electrical Classification	Ingress Protection	Operating Temp	Operating Humidity	Storage Temp
15W	No Ground	Damp Location	-20°C~45°C	0~90%	-20°C~65°C

Spectral Distribution

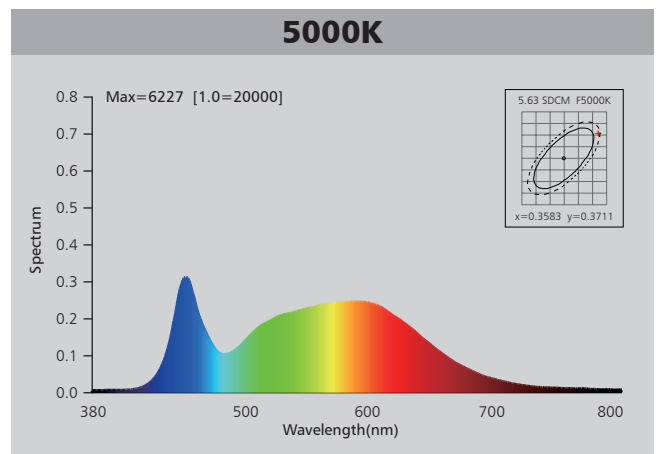
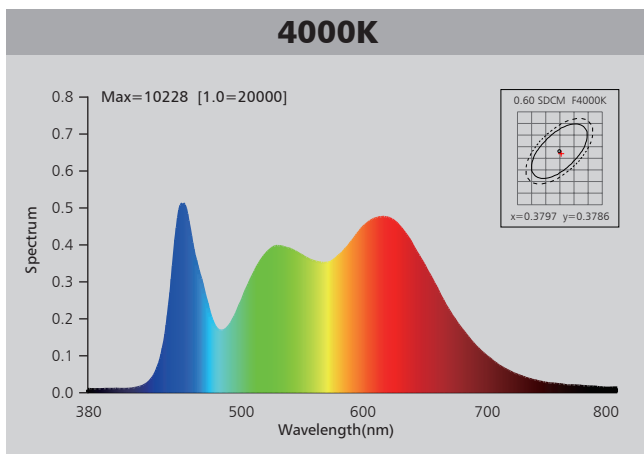
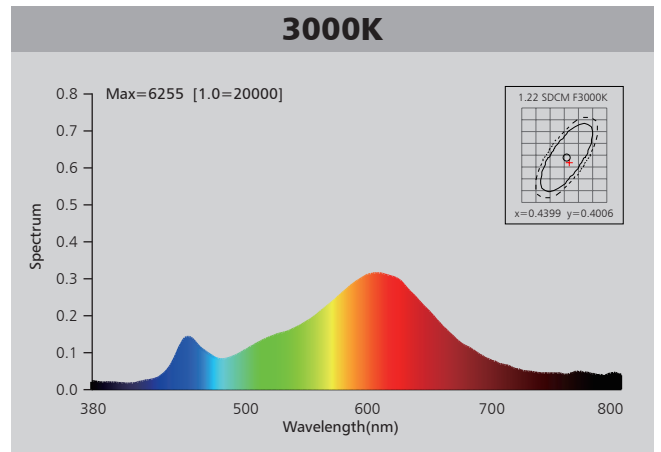
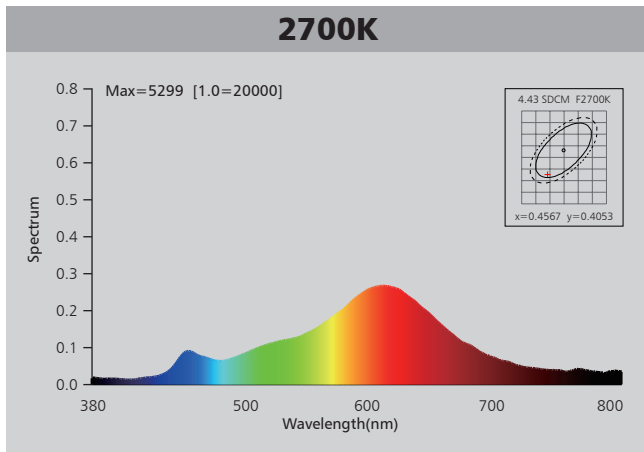

Photometric Diagram

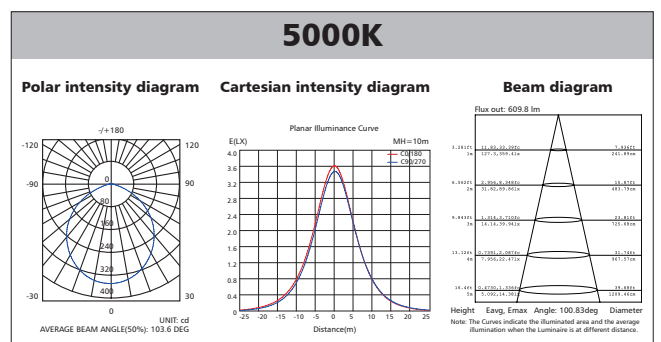
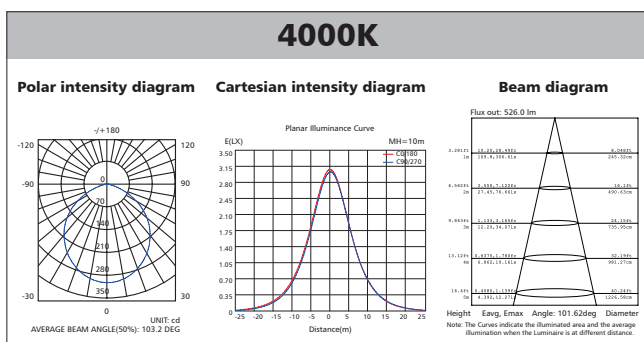
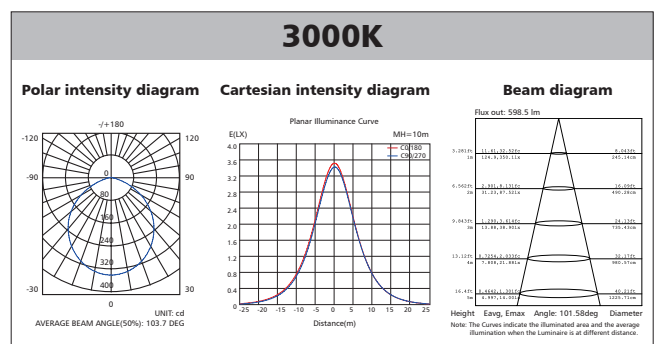
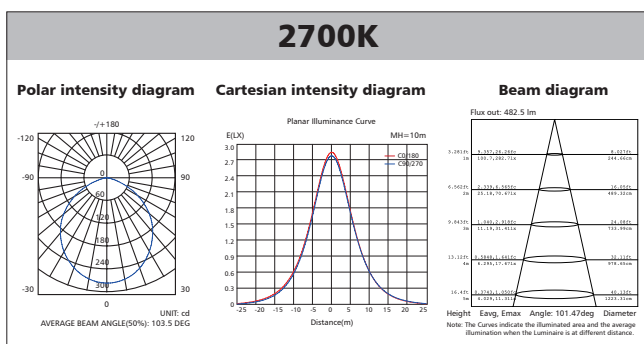

Polar Diagram Comparison

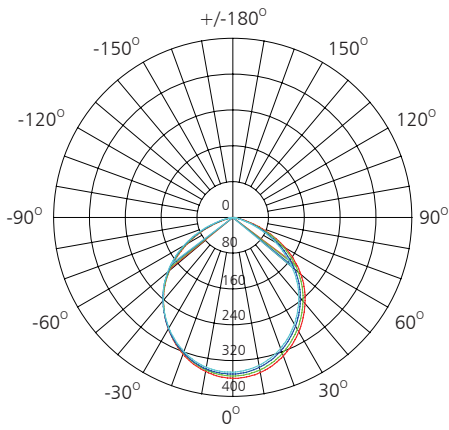

UNIT: cd

- C0/180, 104.0 deg
- C30/210, 103.9 deg
- C60/240, 103.3 deg
- C90/270, 103.1 deg

AVERAGE BEAM ANGLE (50%): 103.6DEG



Driver lifetime & LED light decay rate

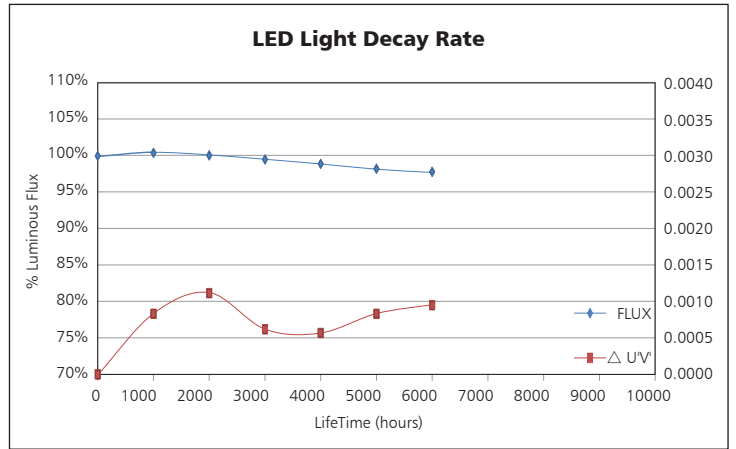
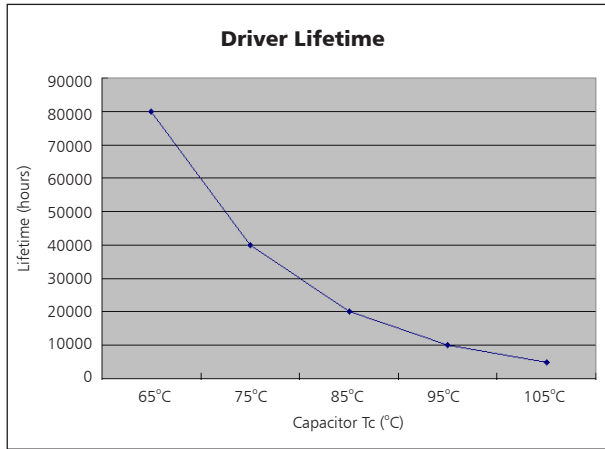

Temperature

- The testing is operated at 25°C
- The lifetime of capacitor, minimum of 5,000 hours if operated at 105°C, will be doubled whenever the temperature drops 10°C.
- The highest withstand temperature of IC, MOS could be 120°C
- The highest withstand temperature of LED junction temperature is 150°C

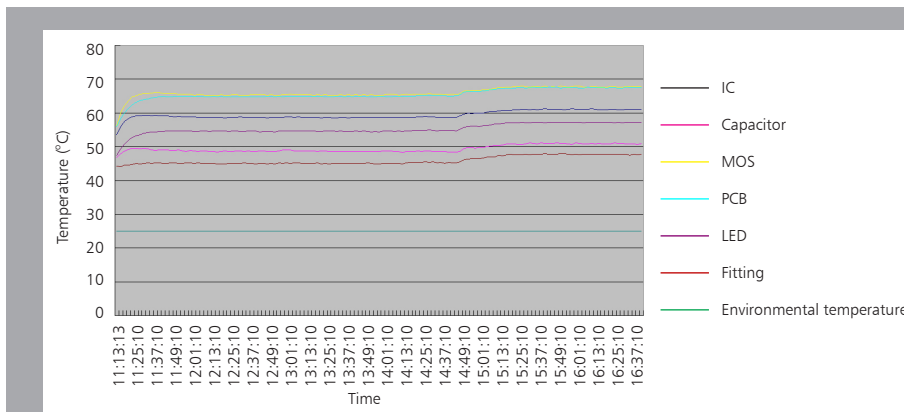

The driver lifespan is based on capacitor working temperature.

Installation

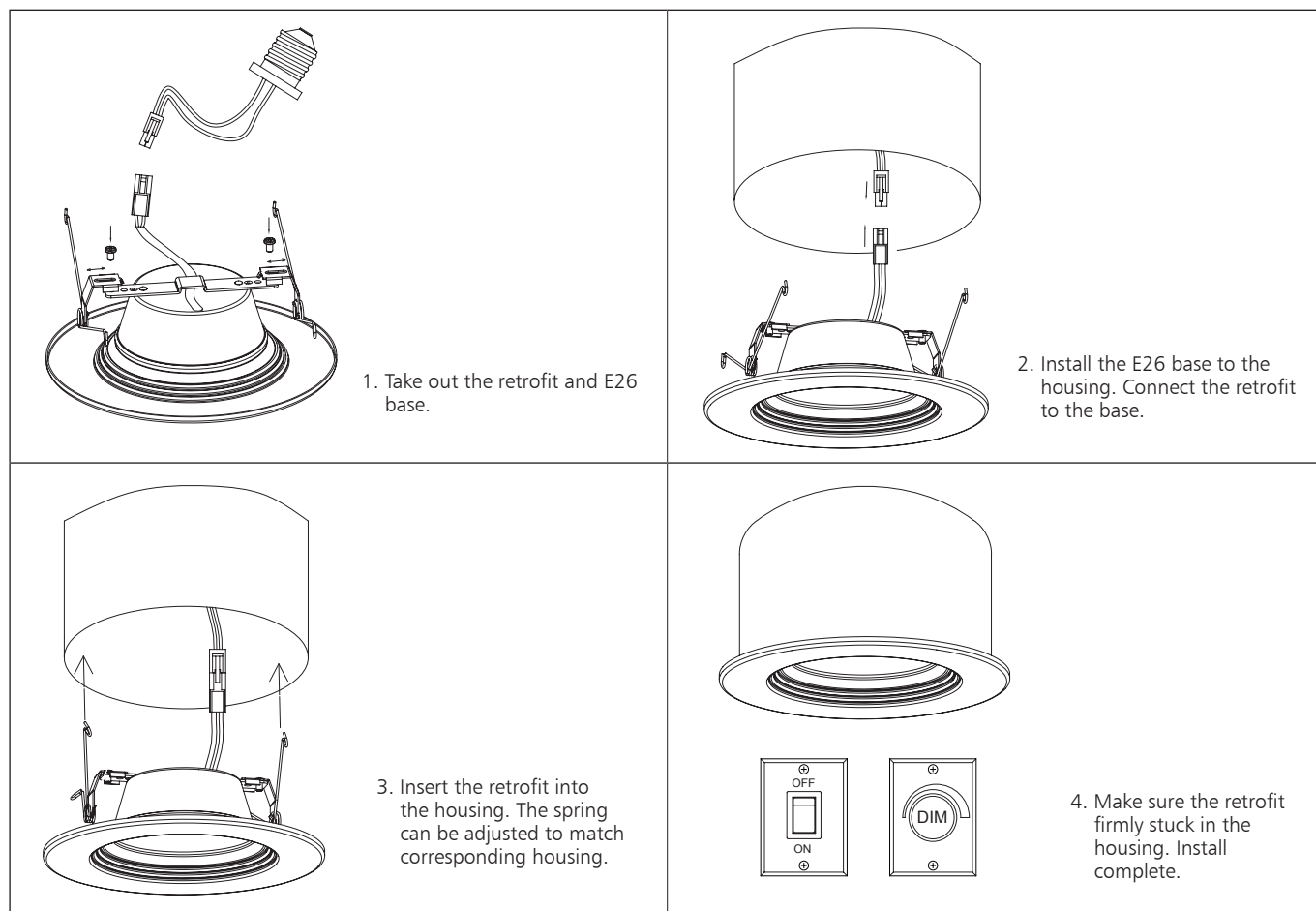

Packaging Information

	SIZE(CM)	N.W/pc (KGS)	G.W.(KGS)	Q'TY(PCS)
Carton	44.5*43.5*43.5	0.17	7.5	24

	CTNS	Q'TY(PCS)	VOLUME(CBM)
20" standard container	325	7800	28
40" standard container	650	15600	56

