



Up-shine[®] Lighting



Technical Application Guide for UP-SHINE LED Downlight

UP-DL100A-7-14.2W-D

Introduction



DL100 Surface mounted LED downlight adopts compact slim design, looks elegant. The special optical diffuser can increase central candela intensity by more than 30%, provide soft and comfortable lighting. Easy to install into most of standard J-boxes.

- Up to 70% energy saving compared to standard CFL
- Long lifetime of 40,000 hours
- 90° wide beam angle
- CCT: 2700K 3000K 3500K 4000K
- No UV/IR light
- Environment friendly, without Mercury or any other hazardous substances

Application notes

- Wet location for indoor use only
- Professional electrician for installation only
- Switch off before installation
- Do not touch when in use
- Keep away from hot steam and corrosive gas

Application Areas

It is designed for general lighting applications in office, supermarket, shop, school, hotel, etc. It is also widely used for public areas, such as stairway, lobby, reception, corridors etc.

Certificate



Product Information

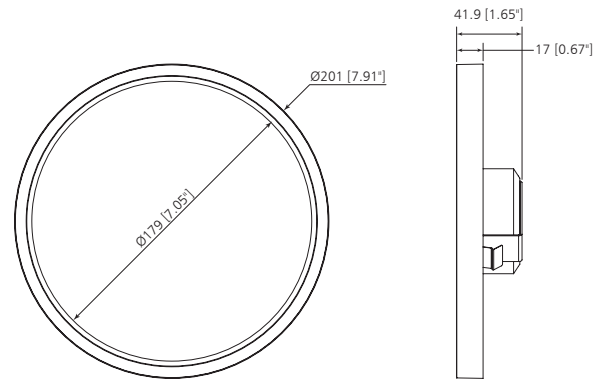

Technical Specifications

Model	Voltage	Power	Power Factor	Lumen (±5%)	Beam angle	CCT	Lifespan	CRI	Dimmable	Dimension
UP-DL100A-7-14.2W-D	AC120V	14.2W	≥0.9	1136	90°	2700K	40000h	≥80	Yes	Ø201*41.9mm
UP-DL100A-7-14.2W-D	AC120V	14.2W	≥0.9	1150	90°	3000K	40000h	≥80	Yes	Ø201*41.9mm
UP-DL100A-7-14.2W-D	AC120V	14.2W	≥0.9	1178	90°	3500K	40000h	≥80	Yes	Ø201*41.9mm
UP-DL100A-7-14.2W-D	AC120V	14.2W	≥0.9	1200	90°	4000K	40000h	≥80	Yes	Ø201*41.9mm

Driver data Sheet

Driver data	DIM
Input rated Voltage	AC120V
Frequency	60Hz
Input Voltage	AC120V
Efficiency	≥78%
Total load Wattage	14.2W±0.5W
Power Factor	≥0.9
Rated input current	≤0.16A
Full load output Voltage	DC24-38V
Rated output current	350mA
Output current range	350mA±5%
Power tolerance	±5%
Current output tolerance	±5%
Dimming range	8%-100%
Dimmer	Triac dimmers
Short circuit protection	PASS
Over voltage protection	PASS
Over temperature protection	PASS
THD	≤20%
Withstand voltage	—

Fixture Compatibility

Rated Wattage	With Ground	Ingress Protection	Operating Temp	Operating Humidity	Storage Temp
14.2W	YES	Wet location	-20°C~45°C	0~90%	-20°C~65°C

Spectral Distribution

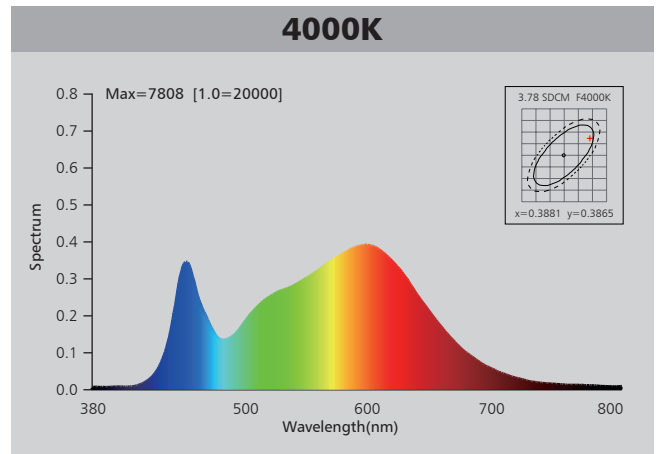
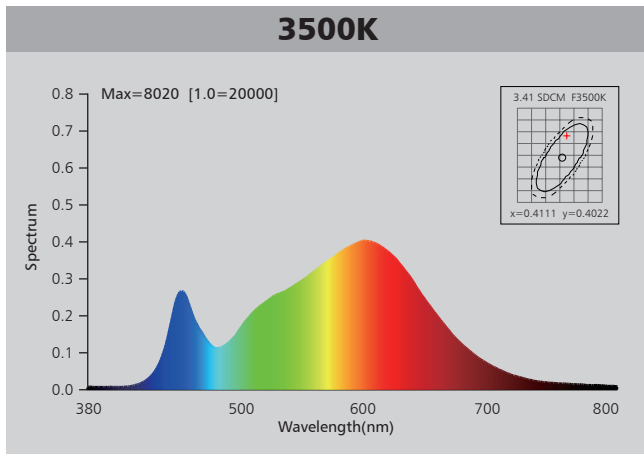
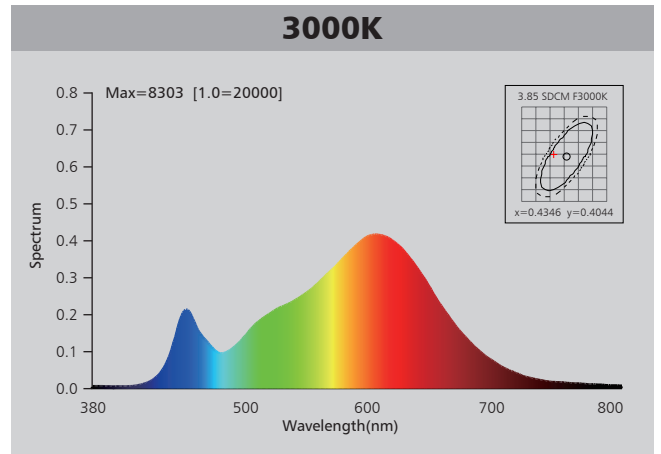
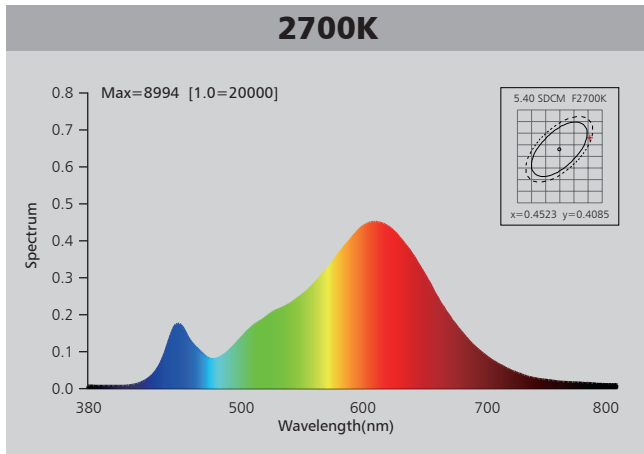

Photometric Diagram

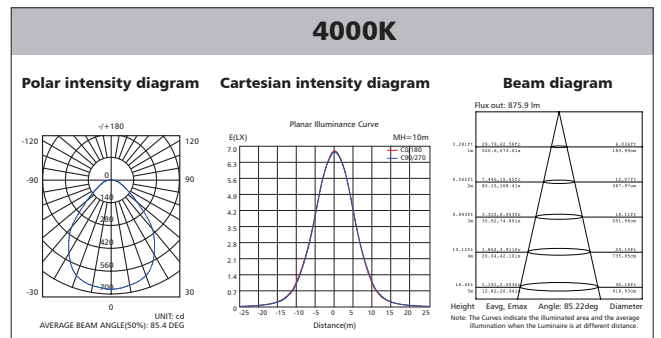
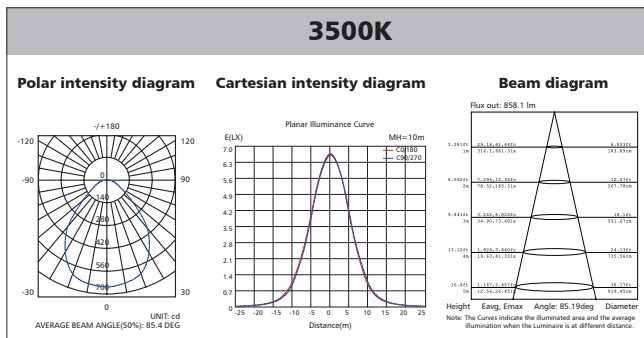
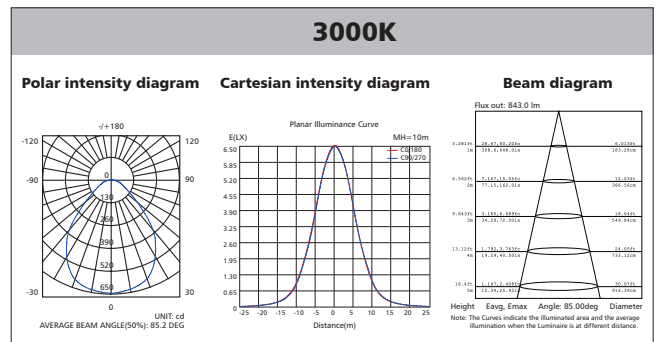
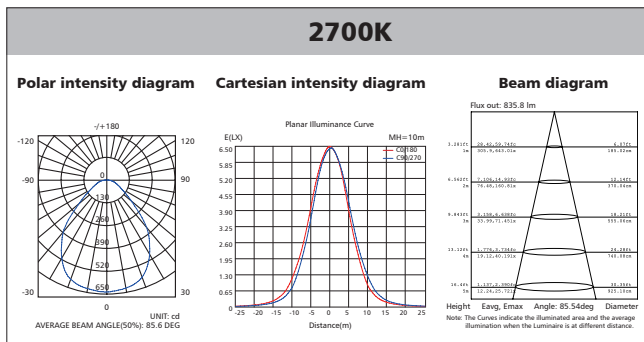

Polar Diagram Comparison

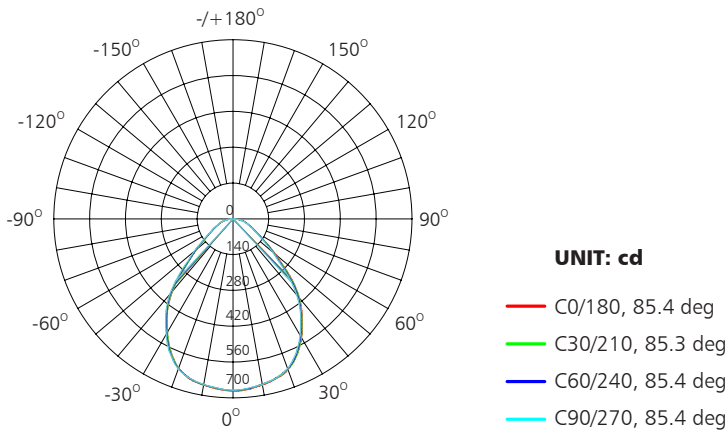

AVERAGE BEAM ANGLE (50%): 85.4DEG

Driver lifetime & LED light decay rate

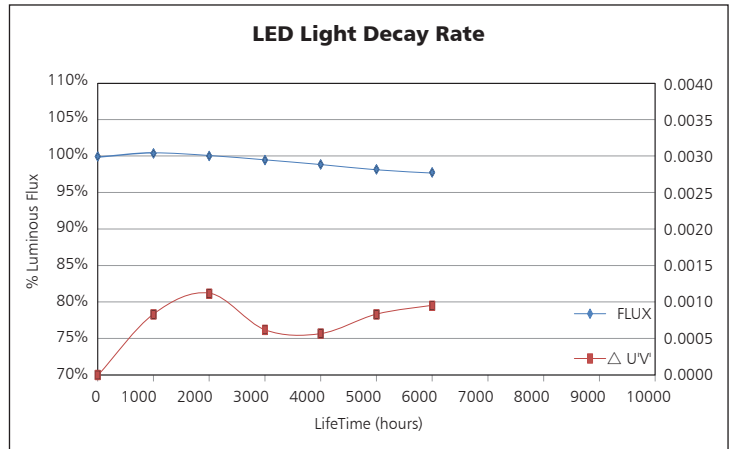
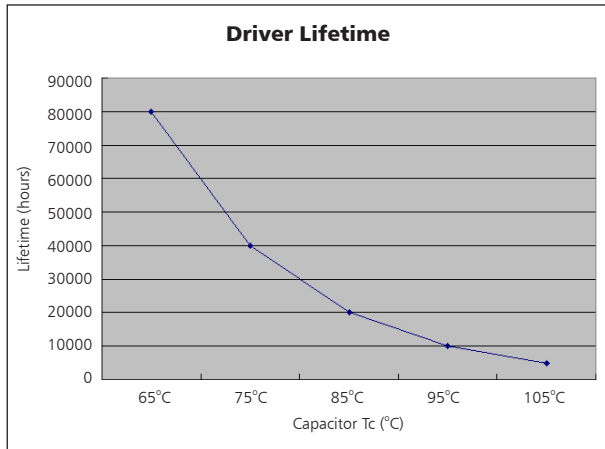

Temperature

- The testing is operated at 25°C
- The lifetime of capacitor, minimum of 5,000 hours if operated at 105°C, will be doubled whenever the temperature drops 10°C
- The highest withstand temperature of IC, MOS could be 120°C
- The highest withstand temperature of LED junction temperature is 150°C

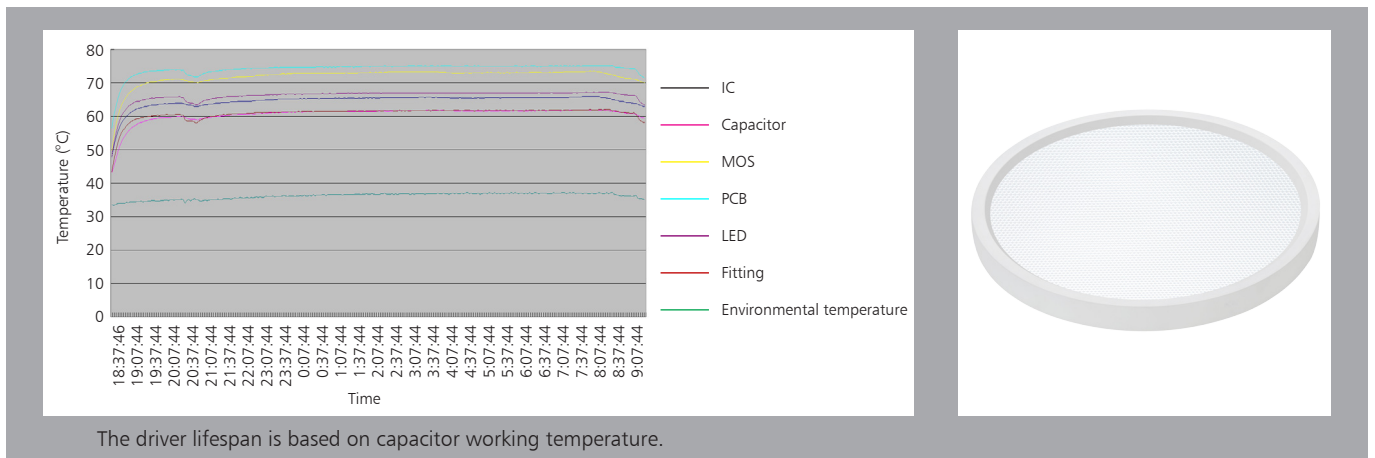

Installation

1. Loosen the screws of octagon J-BOX or Round J-BOX.
2. Align and secure J-BOX MOUNTING PLATE to J-BOX using MOUNTING SCREWS.
NOTE: J-BOX MOUNTING GROUND WIRE must face room side.
Make sure J-BOX MOUNTING PLATE is firmly against the ceiling.
Do not over-tighten MOUNTING SCREWS; this could distort J-BOX MOUNTING PLATE. (FIG.1)
3. Pull supply wires from J-BOX through hole in J-BOX MOUNTING PLATE (FIG.2)
4. For wet location, see FIG 4.
5. While supporting LUMINAIRE BODY, Make electrical connections:
black lead to hot (Black) supply lead; white lead to neutral (White) supply lead.
Un-insulated wires are ground wires (ground J-BOX mounting lead and ground luminaire lead) and must be connected to grounding terminal or ground (Green) supply lead inside J-BOX. Use WIRE NUTS to make connections (FIG.2)
6. Carefully push connections back into J-BOX
7. Align 2 SPRINGS and DRIVER on the LUMINAIRE BODY to the opening in the J-BOX MOUNTING PLATE. Snap LUMINAIRE BODY into plate.

CAUTION: MAKE CERTAIN THAT NO WIRES ARE PINCHED BETWEEN J-BOX MOUNTING PLATE AND LUMINAIRE BODY.

To remove luminaire body from ceiling pull straight down.

Driver replacement: Inseparable luminaire. Do not attempt to service.
Replace entire fixture.

CAUTION: For wet locations. In accordance with Underwriters Laboratories requirements, a line of caulking compound such as acrylic latex or silicone must be placed around the perimeter of backplate also contacting the flange (as shown) to seal against mounting surface keeping water away from the outlet box and back opening. (FIG.4)
cULus listed for wet locations (ceilings).

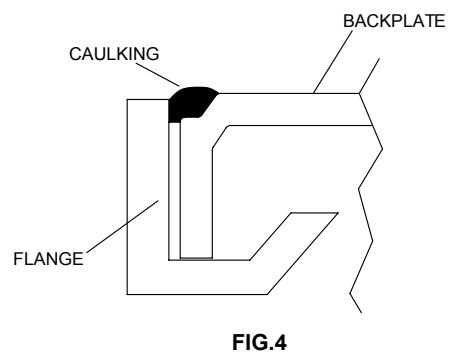
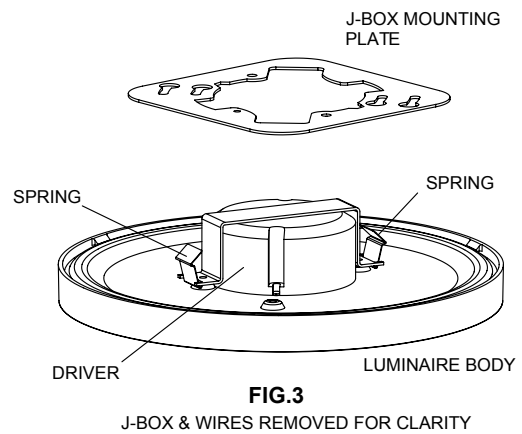
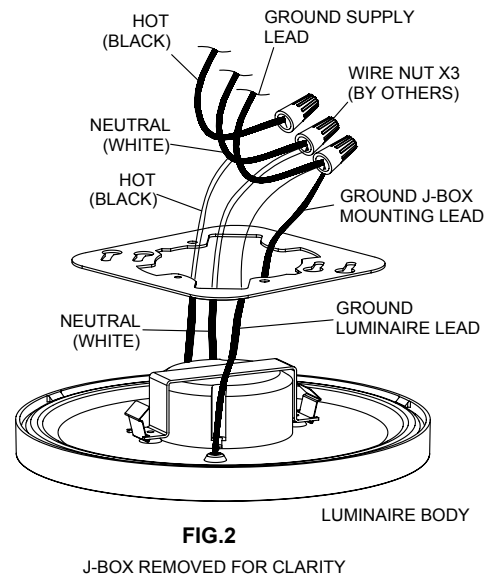
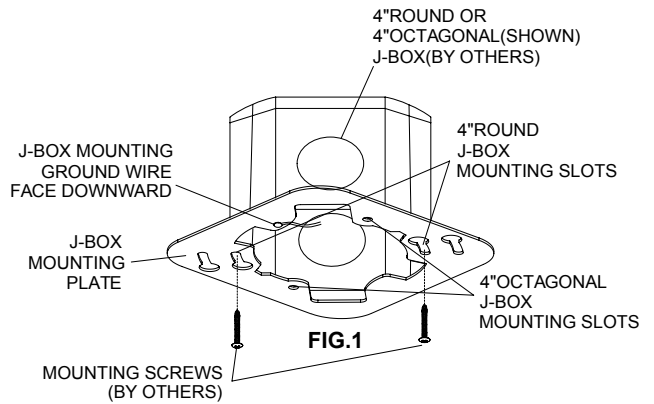

Packaging Information

	SIZE(CM)	N.W/pc (KGS)	G.W.(KGS)	Q'TY(PCS)
Carton	47.5*46.5*39	0.56	16	24

	CTNS	Q'TY(PCS)	VOLUME(CBM)
20" standard container	320	7680	28
40" standard container	640	15360	56

