



Up-shine[®] Lighting



Technical Application
Guide for UP-SHINE
LED Ceiling light

UP-AL40A-11-15W-D

Introduction



AL40 LED surface mounted ceiling light adopts DOB design. Compared with traditional LED ceiling light, AL40 is lighter and more graceful by discarding traditional driver. Lamp body structure is much simpler and more convenient for installation. The PC isolation protective cover inside can effectively prevent hands from touching high-voltage lamp plate, and protect the LED chips as well. It is a cost-effective lamp for both residential and commercial locations.

Features

1. Widely used in indoor lighting places, such as house, office and mall etc;
2. It adopts traditional ceiling light shape structure, suitable for the public aesthetic;
3. Both flat and mushroom shape cover are optional;
4. With easy installation;
5. Special structure lens with 135° beam angle, makes uniform light distribution.
6. CCT: 3000K;3500K;4000K;5000K optional;
7. Adopts high efficiency LED chip;
8. Triac Dimmable;
9. Competitive and cost-effective.
10. DOB Design

Application notes

- Damp location for indoor use only
- The lamp must be installed by professional electrician
- Ensure the power supply is switched off before fitting this product
- Do not touch the lamp when in use
- Keep away from hot steam and corrosive gas

Application Areas

It is designed for general lighting applications in office, supermarket, shop, school, hotel, etc. It is also widely used for public areas, such as stairway, lobby, reception, corridors etc.

Certificate



RoHS

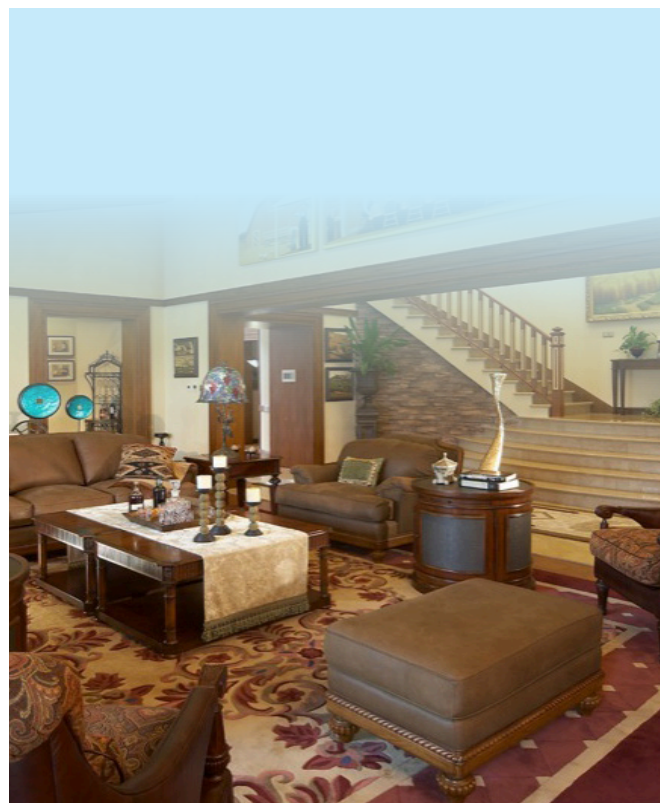

Product Information

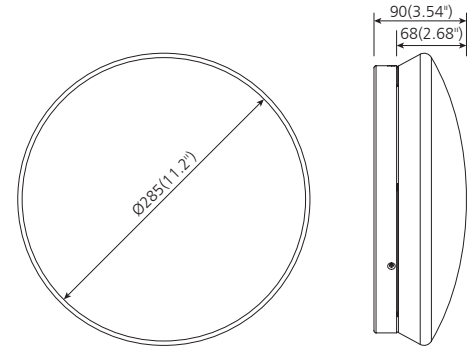

Technical Specifications

Model	Voltage	Power	Power Factor	Lumen (±5%)	Beam angle	CCT	Lifespan	CRI	Dimmable	Dimension
UP-AL40A-11-15W-D	AC120V	15W	≥0.9	950	135°	3000K	50000h	≥80	Yes	Ø285*90mm (Ø11.2"*3.54")
UP-AL40A-11-15W-D	AC120V	15W	≥0.9	1000	135°	3500K	50000h	≥80	Yes	Ø285*90mm (Ø11.2"*3.54")
UP-AL40A-11-15W-D	AC120V	15W	≥0.9	1050	135°	4000K	50000h	≥80	Yes	Ø285*90mm (Ø11.2"*3.54")
UP-AL40A-11-15W-D	AC120V	15W	≥0.9	1100	135°	5000K	50000h	≥80	Yes	Ø285*90mm (Ø11.2"*3.54")

Driver data Sheet

Driver data	DIM
Input rated Voltage	AC120V
Frequency	60Hz
Input Voltage	AC120V
Efficiency	≥70%
Total load Wattage	15W±1W
Power Factor	≥0.85
Rated input current	≤0.15 A
Full load output Voltage	DC120-140V
Rated output current	90mA
Output current range	90mA±5%
Power tolerance	±5%
Current output tolerance	±5%
Dimming range	8%-100%
Dimmer	Triac dimmers
Short circuit protection	PASS
Over voltage protection	PASS
Over temperature protection	PASS
THD	—
Withstand voltage	—

Fixture Compatibility

Rated Wattage	Electrical Classification	Ingress Protection	Operating Temp	Operating Humidity	Storage Temp
15W	With Ground	Damp location	-20°C~45°C	0~90%	-20°C~65°C

Spectral Distribution

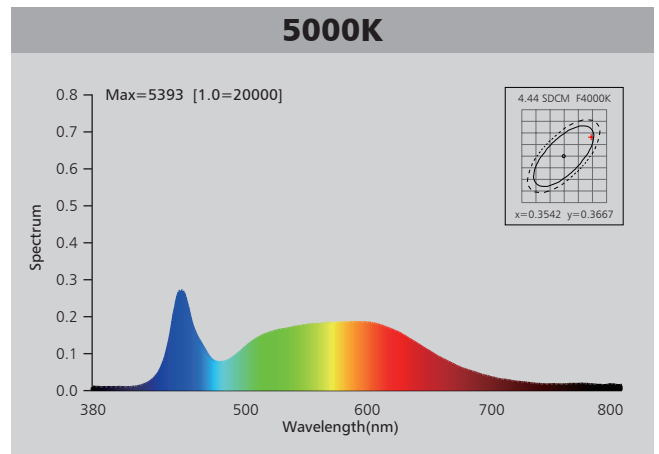
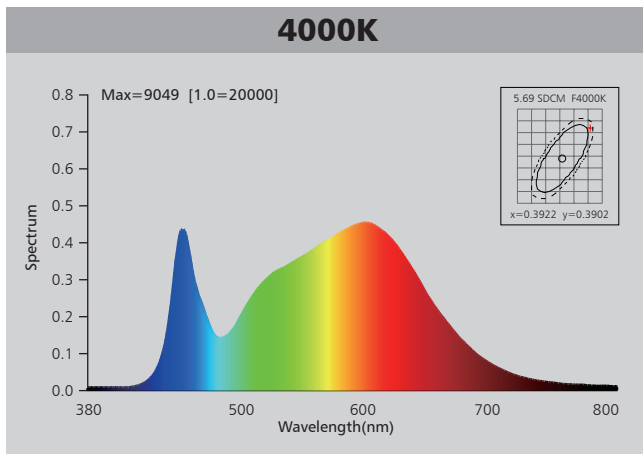
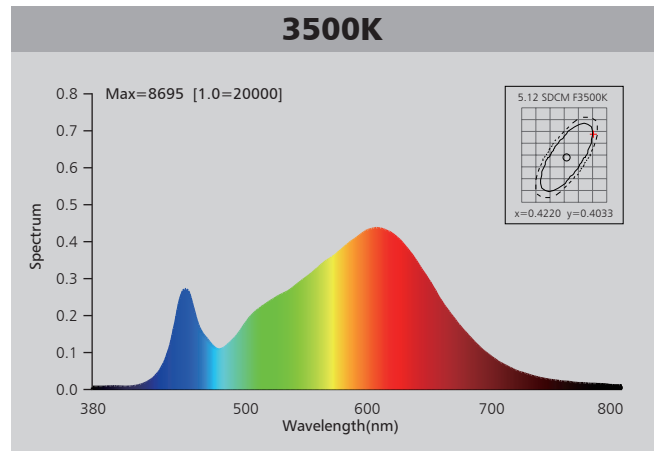
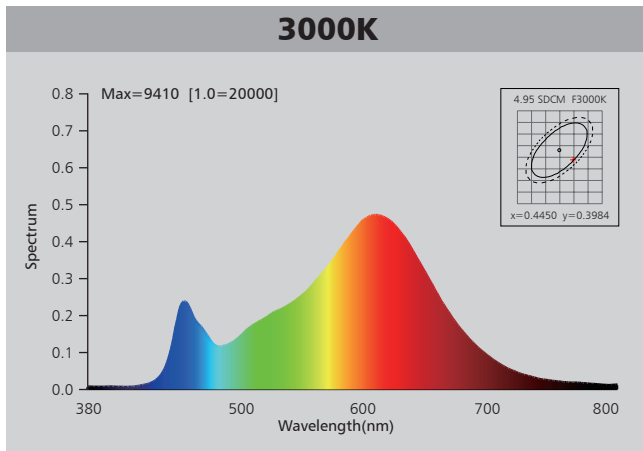

Photometric Diagram

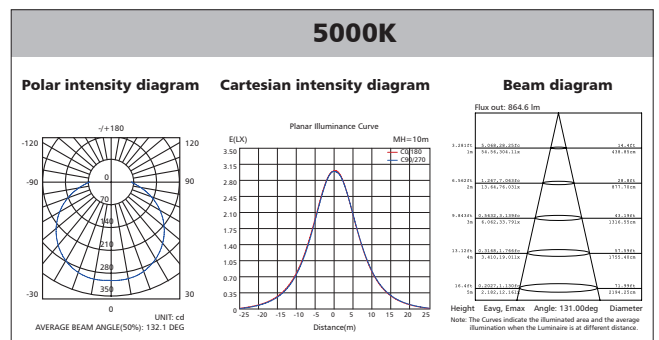
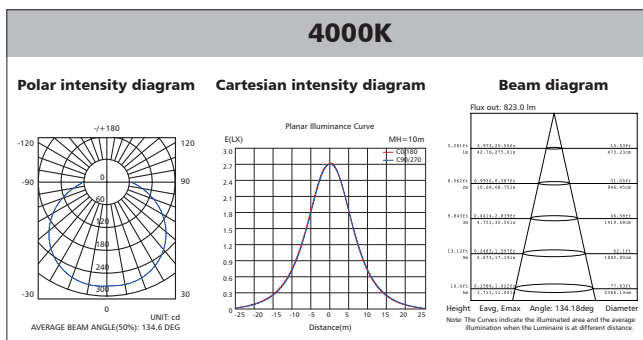
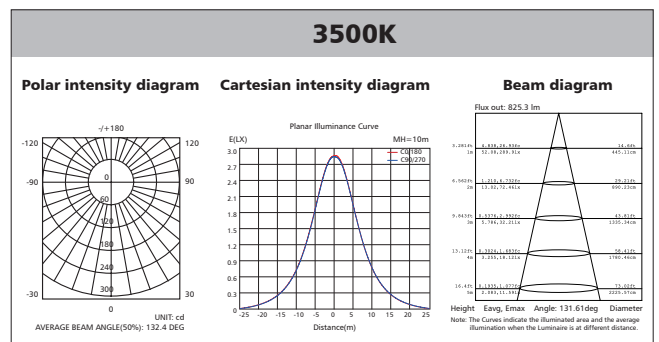
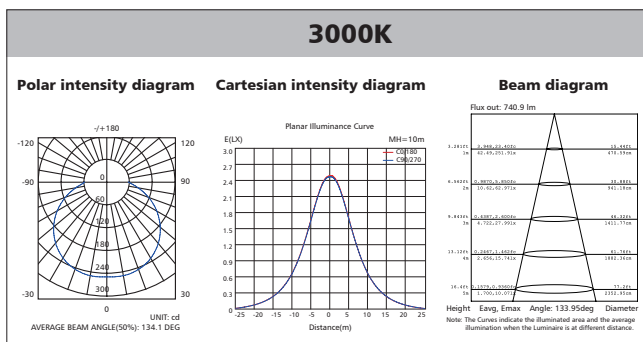

Polar Diagram Comparison

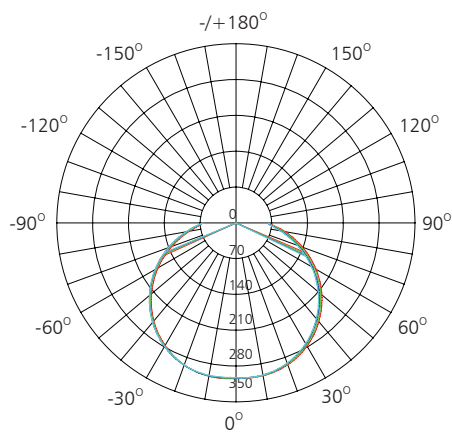

UNIT: cd

- C0/180, 132.2 deg
- C30/210, 132.2 deg
- C60/240, 132.1 deg
- C90/270, 131.7 deg



AVERAGE BEAM ANGLE (50%): 132.1DEG

Driver lifetime & LED light decay rate

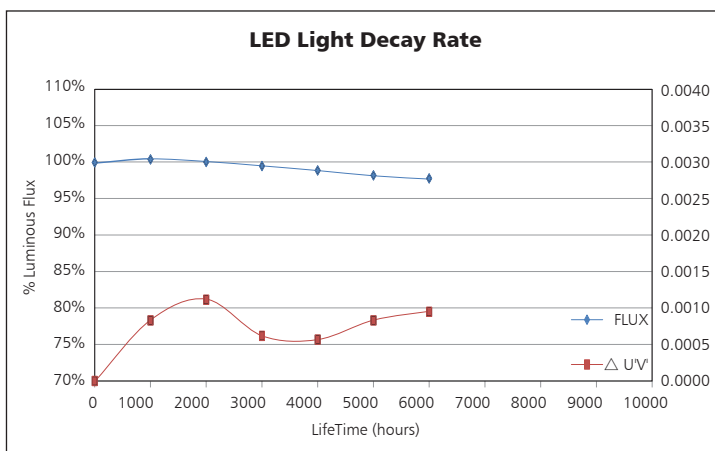
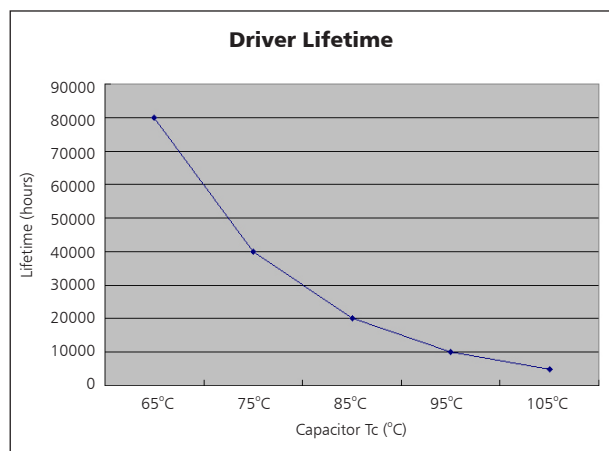

Temperature

- The testing is operated at 25°C
- The lifetime of capacitor, minimum of 5,000 hours if operated at 105°C, will be doubled whenever the temperature drops 10°C
- The highest withstand temperature of IC, MOS could be 120°C
- The highest withstand temperature of LED junction temperature is 150°C

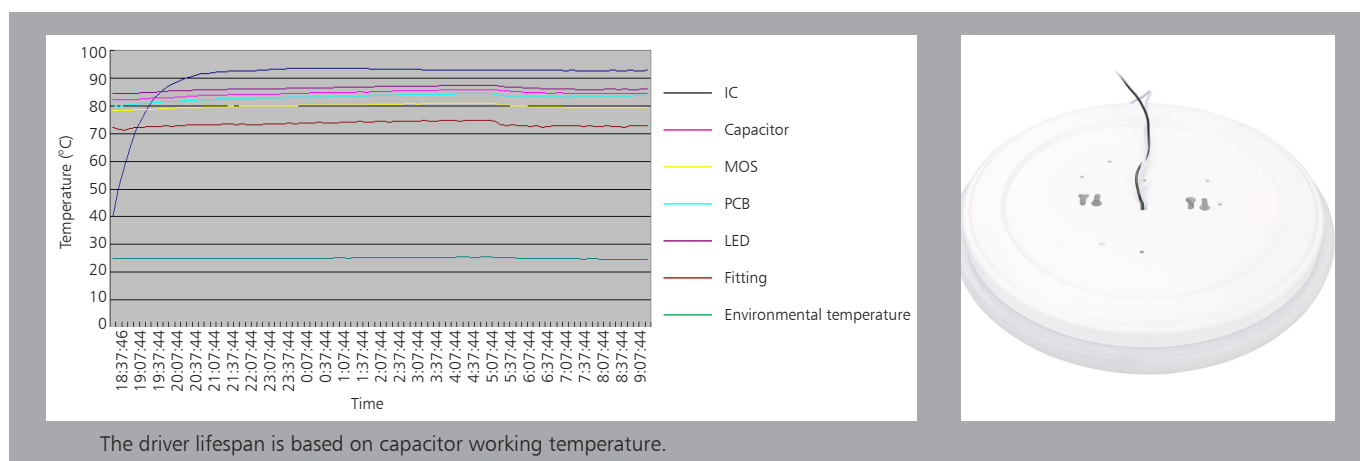

Installation

FIG.1

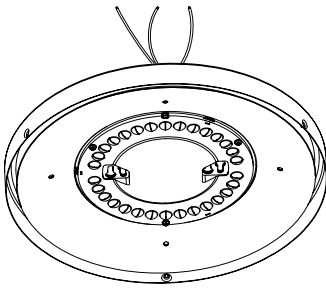

FIG.2

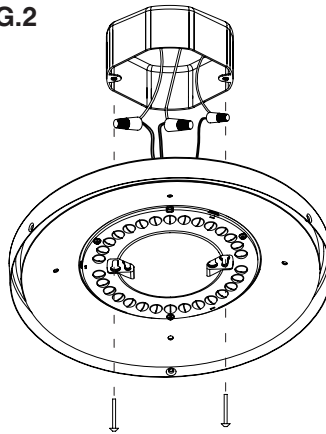

FIG.3

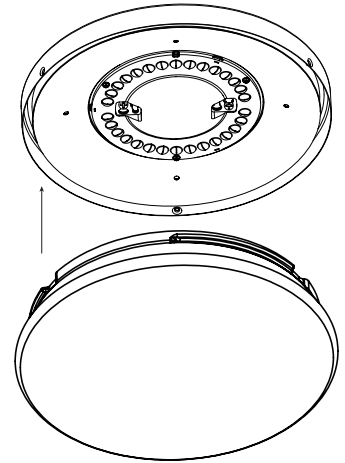
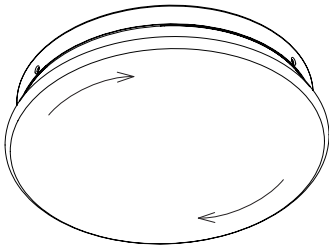

FIG.4



1. Disconnect the power, Place the ceiling lamp base (with light source module) ready. (FIG.1)
2. Connect the white/Black and Green ground wires with wiring cap (FIG.2)
3. Align the chassis with the J-BOX hole, fix the chassis together with J-Box by screws. (FIG.2)
4. Place the lamp cover edge groove with the bump of the chassis, put the lamp cover into the chassis and fix the cover well (FIG.3/4).
5. Installation finished .

CAUTION: MAKE CERTAIN THAT NO WIRES ARE PINCHED BETWEEN J-BOX MOUNTING PLATE AND LUMINAIRE BODY.

Packaging Information

	SIZE	N.W/pc (KGS)	G.W.(KGS)	Q'TY(PCs)
Carton	69.5cm*41cm*35cm (27.36"*16.1"*13.8")	0.55	5	6

	CTNS	Q'TY(PCs)	VOLUME(CBM)
20" standard container	275	1650	28
40" standard container	550	3300	56

